

PLANNING & DEVELOPMENT
DEPARTMENT

Downtown Hyannis Unified Design Regulations and Guidelines

Design Criteria for Downtown Hyannis

~~2023~~2024

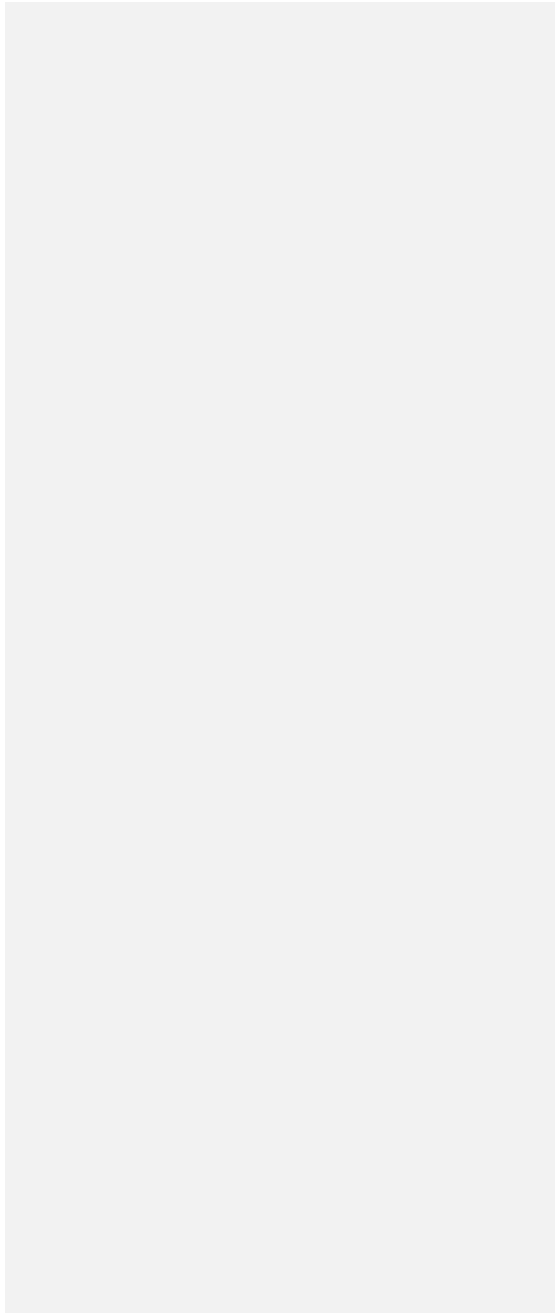

Table of Contents

1	Introduction	4
	The Districts	4
	Design	5
	Methods for Redevelopment and Preservation	5
	Common Building Vocabulary	6
	Historic Significance	7
2	Downtown Hyannis Design Standards – Jurisdiction of Review Map	11
3	Downtown Hyannis Design Standards – Jurisdiction of Review	12
	Hyannis Main Street Waterfront Historic District Commission	12
	Planning Board	13
	Enforcement.....	14
4	Design Standards Review Applicability.....	15
	Hyannis Main Street Waterfront Historic District	15
	Growth Incentive Zone.....	15
5	How to Use these Design Standards.....	16
6	Building Design Regulations and Guidelines.....	18
	Building Design Regulations	19
	Building Design Guidelines	24
7	Site Plan Design Regulations and Guidelines.....	36
	Parking Design Regulations	36
	Parking Design Guidelines	38
	Site Amenities and Landscape Design Regulations	41
	Site Amenities and Landscape Design Guidelines	41
	General Site and Placemaking Guidelines	45
8	Sign Regulations and Guidelines.....	48
	Sign Design Regulations	48
	Sign Design Guidelines	54

Appendix..... 66

- A: Allowable Paint Colors
- B: Native Plant List
- C: Sign Design Checklist
- D: Building Frontage Types

The Planning Board adopted these design standards that shall replace Section 7 of the Design and Infrastructure Plan Design Standards on December 11, 2023. The Hyannis Main Street Waterfront Historic District Commission ultimately did not adopt the standards of the Downtown Hyannis Unified Design Regulations and Guidelines.

The standards herein are not in effect for the Hyannis Main Street Waterfront Historic District Commission.

Introduction

This is the Downtown Hyannis Unified Design Regulations and Guidelines document for exterior improvements to Downtown Hyannis which includes the jurisdictional boundaries of the Cape Cod Commission’s Downtown Hyannis **Growth Incentive Zone** and **Hyannis Main Street Waterfront Historic District**. These two jurisdictional areas overlap. This unified document provides clear guidance for applicants and property owners. It includes reference to the applicable permit granting authority to foster and champion the historic and maritime character of downtown Hyannis with the opportunity to redevelop and define the built environment of Hyannis with quality, character, and charm.

The Hyannis Main Street Waterfront Historic District Commission and Planning Board shall seek to meet annually to review these standards.

The Districts

The purpose of the Downtown Hyannis **Growth Incentive Zone (GIZ)** is to encourage a concentrated mix of residential and commercial uses within Hyannis while ensuring that all growth is properly served by adequate infrastructure. To achieve the goals of the GIZ, the Town will implement planning initiatives, develop decision support tools, make planned infrastructure investments, and enact regulatory changes to support continued public and private investment in the Hyannis GIZ.

A Design and Infrastructure Plan is required for the Growth Incentive Zone as authorized by the Cape Cod Commission. The Design and Infrastructure Plan is a reference manual for developers, designers, town boards, and officials to guide improvements to private properties and public infrastructure in Downtown Hyannis. **This Unified Design Regulations and Guidelines document furthers the Design and Infrastructure Plan, replaces its design standards, and creates a consistent standard for the GIZ and the Hyannis Main Street Waterfront Historic District.** The Planning Board is the permit granting authority for all Special Permit applications within the GIZ.

The **Hyannis Main Street Waterfront Historic District** was created to help protect and preserve the distinctive characteristics of buildings, structures, and places significant in the history and architecture of downtown Hyannis. The Hyannis Main Street Waterfront Historic District Commission is the permit granting authority for all Certificates of Appropriateness and Demolition within the Hyannis Main Street Waterfront Historic District. This Unified Design Regulations and Guidelines document replaces the existing Design Guidelines and Supplemental Design Guidelines.

Design

The diverse and unique buildings of Hyannis are only part of what gives Hyannis its distinct character. Buildings and their sites, including landscaping, parking areas, and lighting must complement and create connections with each other to preserve the Districts' historic character and enhance the visual integrity and quality of the greater region. Acute consideration should be given to specific sites surrounding environmental context, the proposed entrance or shopfront's relationship to the public realm, the neighboring built form, and preferred materials when proposing a new project.

Methods for Redevelopment and Preservation

When considering an architectural improvement in Downtown Hyannis, consider these five forms of redevelopment prior to proposing new construction.

Conservation: The repair of existing historic construction materials by stabilizing and consolidating the damage, instead of removing and replacing the material with new.

Preservation: A technique placing a high premium on the retention of all historic fabric through conservation, maintenance and repair. Reflects a building's continuum over time and the respectful changes and alterations made through successive decades and/or centuries.

Reconstruction: Re-creation of a non-surviving site, landscape, building, structure or object in all new materials.

Renovation: Repairing or modernizing existing buildings while ignoring or disregarding any historic features or significance is highly discouraged, unless a commitment is made to respect historic features and architectural significance, materials used and compatibility with surrounding structures. Lacking such commitment, renovation should not be attempted.

Restoration: Focuses on the retention of materials from the most significant time in a property's history, while permitting the removal of materials from other periods.

Common Building Vocabulary



Details are critical to a building's appearance to the public realm. Consider all details in the image above when proposing a project in addition to the inclusion of window boxes, shutters, landscaping, etc. when appropriate.

Source: City of Salem. Salem Historical Commission. Salem Historical Commission Guideline Notebook, page 41. 2022.

Historic Significance

The historic significance of a structure is evaluated based on architectural integrity, significance of use or design, and age. The most historically significant structures in the Districts are ones representative of the historical and maritime architectural movements, events, commerce, and traditions that collectively symbolize Hyannis.

The Hyannis Main Street Waterfront Historic District includes two National Register Historic Districts. The Municipal Group National Register Historic District, roughly bounded by Main, South, and Pearl Streets, has six contributing properties, including Town Hall, the School Administration Building, and the Hyannis Public Library. The Pleasant Street/School Street National Register Historic District, roughly bounded by Main, School, South, and Pleasant Streets has 51 contributing properties. This district is representative of the mid-19th century maritime heritage of the village. There are also 12 properties individually listed on the National Register of Historic Places. An additional 14 properties have been determined to be eligible for listing on the Register.

National Register designation does not alter the local review process, but it provides a clear indication that a building or site is historically significant. Repairs, alterations, or rehabilitations of historically significant buildings should preserve or restore original architectural elements that give a structure its historic value. Although buildings and structures must be adapted to meet the needs of individual owners, alterations should be made with respect for the structure and its significance to the community and to the Districts.

Preservation of Historically Significant structures with a high to moderate degree of architectural integrity should be preserved in a manner that reflects their original design and construction.

- The primary preservation technique for historically significant structures should be preventative maintenance; routine maintenance using recommended preservation techniques will help retain a structure's historic value.
- Original architectural elements should be restored and reused whenever possible. If building elements are not in a restorable condition, they should be replaced with elements of an identical material and design, when possible.
- Historically significant buildings should not be modified or altered in a way that diminishes the architectural integrity of the structure. Removing or obscuring original materials or decorative elements is not appropriate.
- Whenever possible, historically significant buildings should be adapted and not replaced. At a minimum, preservation of historic façades should be considered as an alternative to building demolition.
- Building materials including siding, masonry, and stone foundations should not be covered, painted, stuccoed without HHDC review and approval.

There are a few distinct use types within the Districts as defined in the previous HHDC Design Guidelines:

Cape Cod Residential

Cape Cod is nationally noted for what has come to be known as the Cape Cod residential style of architecture, which is thought by some to be the most important single contribution the Cape has made to the rest of our country. The Districts have many fine examples of this style of architecture. The Cape Cod House can take three forms: it is full when its center door is flanked by two windows on either side, three-quarter when two windows appear to one side and a single to the other, and half when the front facade displays simply a door and two side-by-side windows. The Cape Cod story-and-a-half house is a purely functional building that is comfortable and local to the surrounding community. The exterior typically consists of 9/6 light sash windows, a paneled door with transom above, and shingled walls, although the south-facing front was sometimes clapboarded. A Cape Cod House often developed a series of ells over time, one room being added at a time, in response to the needs and growth of the family.



Traditional cape and a traditional cape with ells

Early 1900s Commercial

Storefronts and commercial buildings are an important aspect of the Districts' architecture. The majority have two or two-and-a-half stories composed of brick with large display windows, separated by brick piers. The doors almost always have windows, with painted rather than stained or varnished. During the early 1900's, upper floors were residences of the store owner and their family. Today, upper floors are typical used as office space. Frequently larger than neighboring residential structures, commercial buildings have features such as one-over-one or two-over-two windows on upper floors, and projecting cornices. The structures tend to reside right on the sidewalk with minimal to no setbacks and are design to engage pedestrians as they enjoy Main Street.



Figure 1: Hyannis downtown historic photo (left image) and present day (right image)

Source: Hyannis BID, 2023, <https://www.cardcow.com> Publisher: E.D. West Co

Reuse and Rehabilitation Structures with historic significance, but diminished architectural integrity should be rehabilitated and restored whenever possible.

- Building renovations should be harmonious with the original structure in style, form, and materials.
- Historic photographs or records can be used to research the building's original appearance and style. The Town's Planning and Development Department may be able to help you locate these resources.

Additions and Alterations to historically significant buildings should leave the original building intact, and not significantly alter the original structure's appearance or character. Note that long-standing additions may be considered historic, and may be treated as such.

- Additions should be viewed as "removable": if the addition were to be removed, the original structure, and its significant features, would remain as it appeared prior to the alteration.

- Additions should be designed, placed, and sized with respect to the original building. The original historic building should remain prominent, and any additions subsidiary. Where possible, additions should be deemphasized by being placed at the rear of the structure, or set behind the building's front façade.
- Additions should be scaled in proportion with the original building and should not overwhelm it.
- Materials and textures should be compatible, but not necessarily identical with the original building.
- If considering a roofline addition, existing historic dormers should be preserved if possible. New dormers should be narrow, preferably only one window wide. Gable or hipped-roof dormers are recommended over shed dormers.

2

Downtown Hyannis Design Standards - Jurisdiction of Review Map

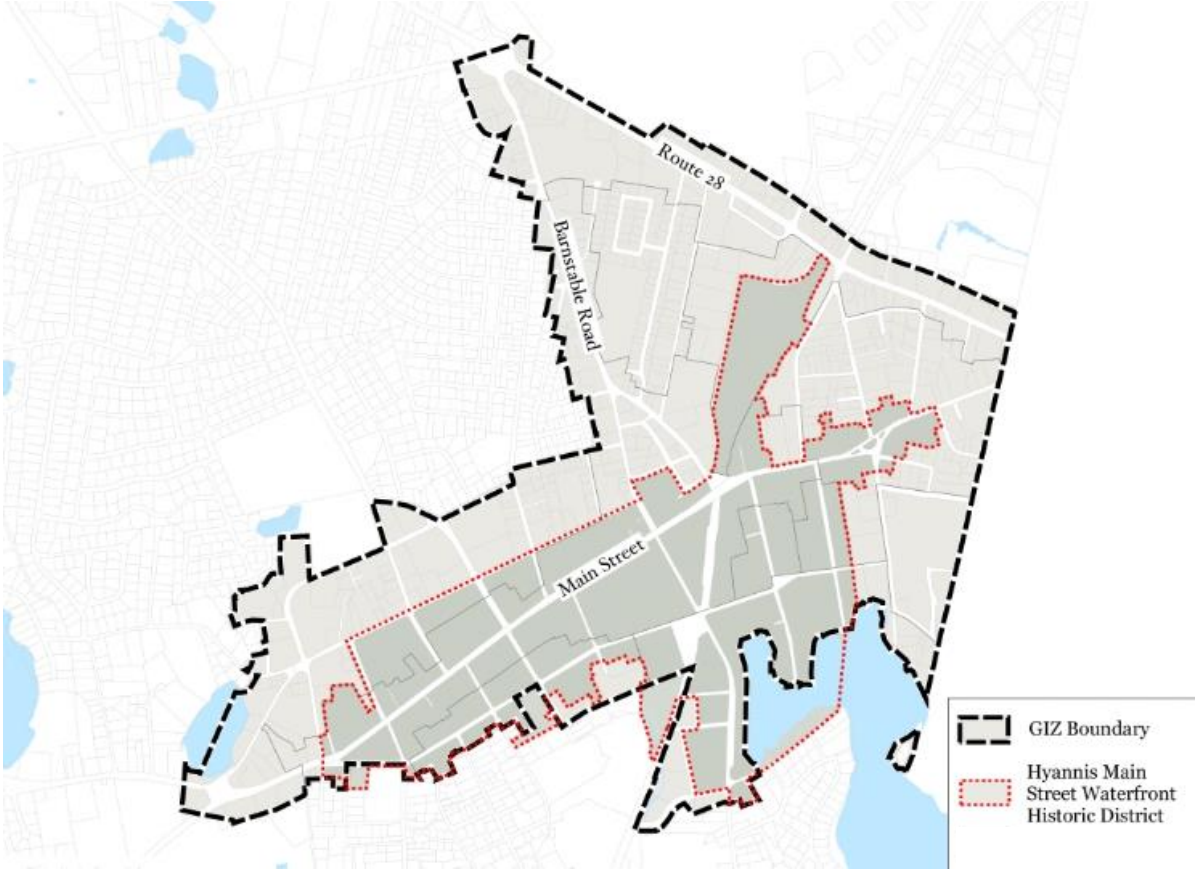

Downtown Hyannis Design Standards - Jurisdiction of Review

Hyannis Main Street Waterfront Historic District Commission

Hyannis Main Street Waterfront Historic District Ordinance has been adopted pursuant to Chapter 40C of the General Laws of the Commonwealth of Massachusetts, as amended and has been codified under General Ordinance §112 Historic Properties. **Below please find a portion of the Ordinance defining the purpose and jurisdiction as stated in the Ordinance.**

General Ordinance §112 Historic Properties, or as amended, Purpose and Jurisdiction.

§ 112-24 Purpose.

The purpose of this article is to promote the educational, cultural, economic and general welfare of the inhabitants of the Town of Barnstable, and the Town's unique community character, through the preservation and protection of the distinctive characteristics of buildings, structures, and places significant in the history and architecture of Barnstable, and through the preservation, maintenance and improvement of appropriate settings for such buildings, structures, and places, and the encouragement of new design which is compatible with the existing historical and community character, and through the benefits resulting to the economy of said Town by preserving and enhancing the amenities and historical aspects of the various villages and areas which make Barnstable a desirable place to live and for tourists to visit.

and

§ 112-29 Commission jurisdiction.

A. Except as this article may otherwise provide, no building, structure, setting or part thereof within the district shall be constructed, demolished, moved or altered in any way that affects any exterior architectural feature subject to public view until the Commission shall first have issued a certificate of appropriateness, certificate of nonapplicability, or certificate of hardship with respect to such construction, demolition, movement, or alteration.

B. No building permit for the construction of any building or structure or for the alteration of any exterior architectural feature within the district which is subject to public view shall be issued by the Town or any department thereof until a certificate of appropriateness, certificate of nonapplicability, or certificate of hardship has been issued by the Commission as required under this article, except that the

Building Commissioner may issue a temporary sign permit for a period not to exceed 60 days for a temporary sign no larger than eight square feet on a commercial premises, provided that size is in conformance with the Town's Sign Code and:

- (1) The applicant files a date-stamped copy of the application for a certificate of appropriateness, certificate of nonapplicability, or certificate of hardship from the Historic District Commission.
- (2) Should the Historic District Commission deny the application, use of the temporary sign should not be permitted beyond the end of the twenty-day appeal period of the decision made by the Historic District Commission.
- (3) Should the applicant appeal the denial of the application, and should the appeal be denied, use of the sign should no longer be permitted as of the day on which the Appeals Committee makes this decision.

C. No permit for the demolition, razing, movement, or removal of a building or structure, or parts thereof within the district which is subject to public view shall be issued by the Town or any department thereof until a certificate of appropriateness, certificate of nonapplicability, or certificate of hardship has been issued by the Commission as required under this article.

Planning Board

A Design and Infrastructure Plan is required as part of the Growth Incentive Zone established by the Cape Cod Commission. The Design and Infrastructure Plan applies to new development and redevelopment, with the exception of single-family residences, in the Downtown Hyannis Zoning Districts. The Downtown Hyannis Zoning Districts ~~are contained within~~ ~~make-up~~ the Growth Incentive Zone. The Design and Infrastructure Plan was originally adopted pursuant to Section 240-24 of the Barnstable Zoning Code and established building and site design standards for all development within the Downtown Hyannis Zoning Districts and creates a set of guidelines to anticipate and direct expected growth. In 2023, the Town updated the Zoning Code to incorporate form-based zoning to Downtown Hyannis and developed enhanced design standards. The following unified design standards shall replace the current development design standards found in the Design and Infrastructure Plan. The Planning Board shall use these unified design standards as the Permit Granting Authority for all projects within the Downtown Hyannis Zoning Districts.

Zoning Ordinance §240-24.1.3 Downtown Hyannis Zoning Districts General Provisions, or as amended.

§240-24.1.3 General Provisions

A. Applicability

1. Where the provisions of Sections 240-24.1.1 through 240-24.1.13 conflict with those found elsewhere in the Barnstable Zoning Ordinance, the provisions of this Section shall apply.

2. The provisions of the Barnstable Zoning Ordinance § 240-6.C (3) shall not apply within the Downtown Hyannis Zoning Districts.
- B. Development Review
1. The Planning Board is the Special Permit Granting Authority (SPGA) for all development within the Downtown Hyannis Zoning Districts.
 2. Development within the Downtown Hyannis Zoning Districts, excluding single-family residences, must comply with Article IX, §240-103, site development standards, and the Design and Infrastructure Plan.
 - (a) The Planning Board shall establish a Design and Infrastructure Plan (DIP) which shall be adopted after a public hearing.
 - (b) In conjunction with the Formal Site Plan Review required by Article IX Site Plan Review, Development and Modification that meets or exceeds the thresholds established in Subsection (i) below in the Downtown Hyannis Zoning Districts shall be reviewed by the Building Commissioner or his designee at a public meeting at which public comment shall be allowed, with notice of such meeting to be provided in accordance with the notice requirements of sections 18-25 of M.G.L. c. 30A, the Massachusetts Open Meeting Law; provided that the requirements of the Open Meeting Law shall not otherwise apply to such meeting.
 - (i) Development of a principal building(s) or new parking lot, Modifications of existing structures that result in an increase of 5,000 or more square feet, or the expansion or modification of an existing surface parking lot containing twenty-one (21) or more parking spaces that increases the number of parking spaces by five (5) or more.
 - (ii) Prior to the Formal Site Plan Review meeting, notice of the meeting shall be mailed to property owners whose properties are within 300 feet of the subject property, with such notice postmarked at least ten days in advance of the meeting.

Enforcement

The Building Commissioner shall be charged with the enforcement of this General Ordinance §112 Historic Properties and the Town of Barnstable Zoning Ordinance §240-24.

Design Standards Review Applicability

Hyannis Main Street Waterfront Historic District

Administrative Review

The Chair of the Hyannis Main Street Waterfront Historic District Commission or a designee, who is appointed by the Chair, and voted on by the Commission, shall review all ordinary maintenance, repair, repainting, or replacement of any exterior building or site feature within the Hyannis Main Street Waterfront Historic District which does not involve a substantial change in design, material, color, or the outward appearance for compliance with this document. Replacement shall be in-kind, in size, color, and material. **All administrative review approvals shall be provided to the Commission at the next public meeting. No additional approval shall be necessary.**

Hyannis Main Street Waterfront Historic District Commission Review

No building, structure, setting or part thereof within the Hyannis Main Street Waterfront Historic District shall be constructed, demolished, moved or altered in any way that affects any exterior architectural feature subject to public view until the Commission shall first have issued a Certificate of Appropriateness, Certificate of Nonapplicability, Certificate of Demolition or Certificate of Hardship with respect to such construction, demolition, movement, or alteration. All formal applications before the Commission will be reviewed for compliance with this document.

Growth Incentive Zone

Administrative Review

Planning and Development and/or Building Commissioner's staff shall review all proposed projects to construct within the Growth Incentive Zone that do not require zoning relief for compliance with this document.

Planning Board Review

The Planning Board is the Special Permit Granting Authority (SPGA) for all development within the Downtown Hyannis Zoning Districts as well as lead negotiator for all Regulatory Agreements. All projects proposed within the Growth Incentive Zone that require zoning relief will be reviewed

by the Planning Board for compliance with this document. Any application made to the Planning Board within the Hyannis Main Street Waterfront Historic District, the Commission shall be provided notice at their next regularly scheduled meeting.

How to Use these Design Standards

The Design Standards consist of both Regulations, which are mandatory, and Guidelines, which are advisory. The Guidelines are preferred recommendations regarding proposed project(s) for the matters which are outside the scope of the applicable Regulation.

Hyannis Main Street Waterfront Historic District Design Regulations

The following Regulations are **requirements** for all applications within the Hyannis Main Street Waterfront Historic District and shall be adhered to unless specifically waived by the Commission. When overlapping jurisdiction, the Planning Board shall also require the applicable regulations when considering Special Permit applications.

Downtown Hyannis Design Guidelines

The following Guidelines ~~apply to are recommendations for~~ all applications within the Hyannis Main Street Waterfront Historic District. Additionally, the Guidelines are **strongly recommended** for all new development and redevelopment, with the exception of single-family residences, in the Growth Incentive Zone and shall be considered by the Planning Board for all Special Permit applications seeking zoning relief and by Planning and Development for all as-of-right projects.

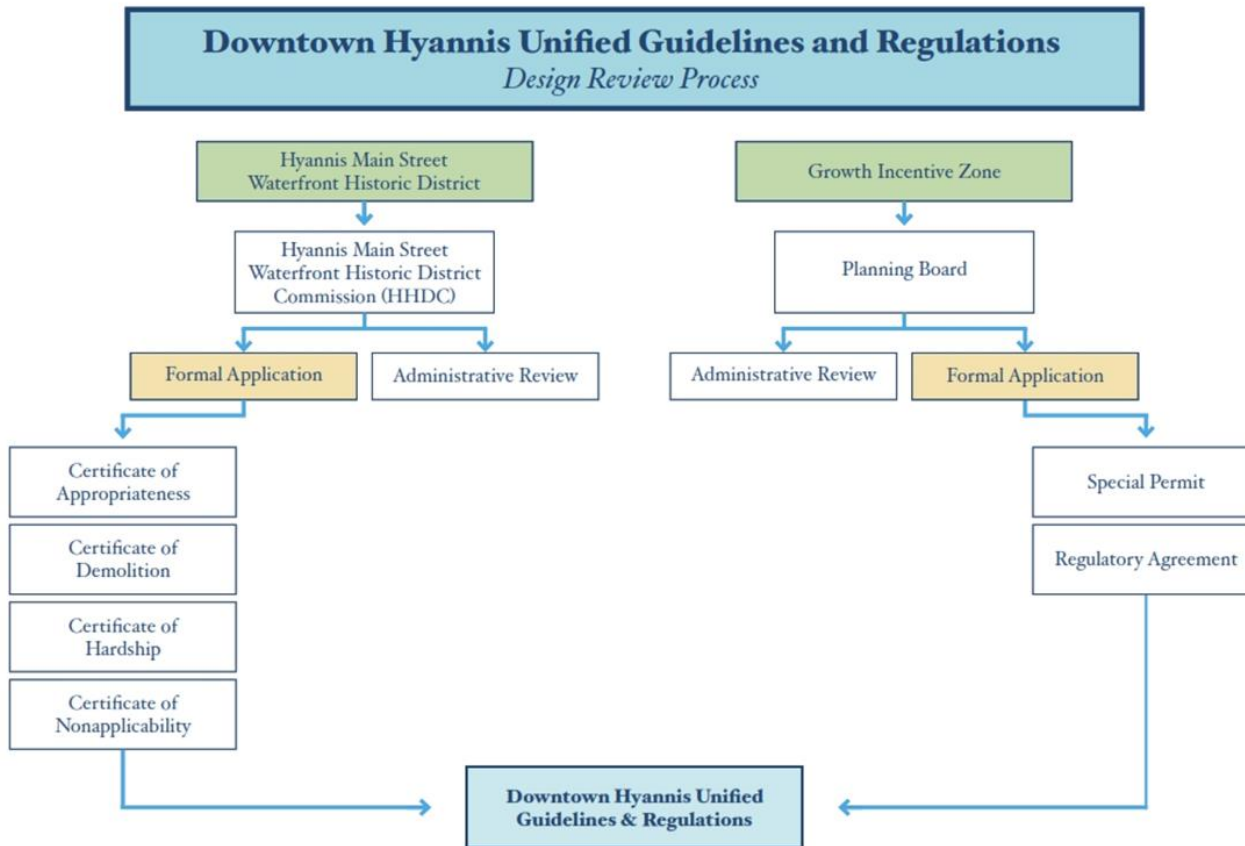

Building Design Regulations and Guidelines



Model of important design features to consider.

Commented [JK1]: Remove image and mark page as Reserved

I. Building Design Regulations

A. Building Form

The building form requirements below are meant to break down the mass of larger proposed buildings and additions so they fit in with existing buildings constructed at a time when developers and businesses built smaller footprint buildings. This break down in massing provides for a varied relationship with the sidewalk. The regulations also acknowledge that existing buildings, even if larger in scale, were the result of a series of additions over time and new constructions and additions shall continue that historic development pattern.

a. Facade Length and Rhythm (Figure 2a &b)

i. The facade of any building greater than one hundred (100) feet in width must be divided vertically by a recess or an offset at least seven (7) feet deep and ten (10) feet wide and designed as two (2) or more distinct facades of differing architectural treatment so that the building appears to be multiple buildings. Modifications to the facade of existing buildings are exempt.

ii. Facades shall be no wider than fifty (50) feet without a change in roof shape/height and a change in material or interruption of the wall plane through such architectural features as balconies, bays and/or oriel windows. A Building's height shall substantially change every 100 linear feet, maximum, by a reduction or addition of a minimum of 10 feet. Building heights are encouraged to vary more often than every 100 linear feet. 100 linear feet is the maximum length prior to height variation.

iii. To retain the historic form and massing of the neighborhood, a Building's foundation shall not exceed 175 linear feet in any given direction. Multiple primary structures are encouraged.

~~iii~~-iv. In order to maintain neighborhood historic character, an abutting structure's building height shall be considered when proposing new construction. The proposed elevation's building height directly abutting an existing structure on an abutting property shall not be greater than ~~or less than~~ 15 feet. The moderate height increase shall be maintained for no less than 30 linear feet before an additional increase in height is considered.

~~iv~~-v. When appropriate, the strategies outlined above shall be reinforced by complementary but contrasting cladding type or color and/or different windows, doors, and trim details.

vi. The compositional rhythm created by the strategies above shall reflect and continue the cadence and scale of facades on the street.



Figure 2a: Example of Desired Residential Facade height and Rhythm

Commented [JK2]: Add a second image with commercial on first floor as Desired Mixed Use Facade Height and Rythm

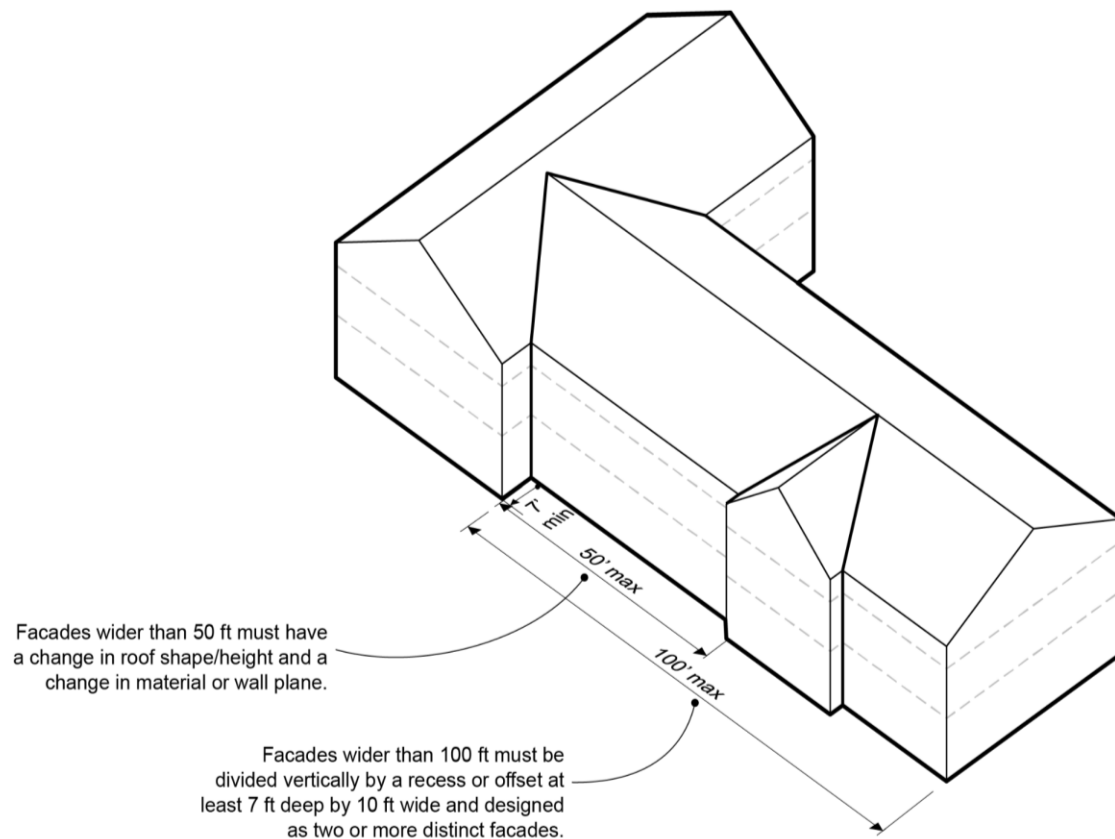

Figure 2b: Facade Length and Rhythm

B. Façade Treatment

a. Materials

- i. Aluminum or vinyl siding are prohibited.
- ii. High-intensity, reflective, and metallic materials are prohibited.
- iii. Window and door trim is required and should be proportional to the size of the windows or doors, relative to the size of the surrounding wall. Additional detail at the edge of the trim, like a scotia to create an additional shadow line, is strongly encouraged. Please note that the use of only a J-channel siding trim at the edge of an off-shelf clapboard cladding system, without a trim board, is prohibited (see Figure 3).
- iv. A cornice is required where the wall meets the roof, including the gable end and where the wall meets roof eaves. In order to create a shadow line that is proportional to the overall building mass, cornices need to have a profile or should be built up of at least two pieces of flat stock.



Figure 3: J-channel siding trim at the edge of an off-shelf clapboard cladding system prohibited. Proper trim required.

b. Color

- i. Refer to the appendix for allowable paint colors. All colors shall adhere to those listed in the appendix. If a waiver is requested the Commission may consider items selected from period-appropriate colors within the [Historic New England Paint Colors of America](#). ~~Color requirements do not apply to signage~~ All signage and logos ~~but shall take into consideration historic surroundings when applying.~~
- ii. Gutters and downspouts shall be the same color as the trim or copper.

c. Awnings/Canopies

- i. Awnings should fit within vertical architectural features and between decorative pilasters.

C. Fenestration

- a. Vinyl windows are only allowed if they have the appropriate character for Cape Cod.
- b. The following window types are allowed on the front façade for residential uses: Double-hung windows are preferred, Casement and tilt/turn windows which provide more airtight seals are permitted as energy-efficient alternatives to double-hung windows, and French doors when leading to balconies are recommended.
- c. Commercial windows on the first floor may vary however, highly reflective and dark-tinted glass are prohibited.
- d. Sliding doors are prohibited along front facades.
- e. Metallic and clear anodized aluminum framing is prohibited on storefront windows and doors.
- f. Window glass. Both residential and commercial windows shall use non-reflective glass for windows, including storm windows. Dark tinted glass is prohibited.
- g. Window screens. Insect screens shall be placed on the outside of windows and patio doors.

D. Frontage Zones

a. Building Entrances

- i. Refer to Table 11 ~~of the Barnstable Zoning Ordinance (also found in Appendix D):~~ Frontage Types in the Barnstable Zoning Ordinance for permitted and non-permitted frontage types in the different Downtown Hyannis Zoning Districts. Entry patios are strongly encouraged.

b. Shopfronts

- i. Vinyl, metal or plastic awnings or canopies are prohibited

E. Rooftop Mechanicals

- a. Nonhabitable architectural features including, but not limited to, mechanical, vents, telecommunications, or exhausts, etc. shall be screened so not to be visible from the public way.

II. Building Design Guidelines

A. Building Form

a. Massing

- i. Buildings are composed of one or more massings and various optional building components that are assembled to make a single building complex. Designing a main massing with smaller attached submassings can help reduce the apparent scale and bulk of a large building.
- ii. The assembly of massings and building components should differ for buildings on abutting lots, except in circumstances where lot width restricts the assembly options that are available.
- iii. Zero lot lines are encouraged for any building contributing toward the frontage buildout for any lot fronting Main Street.

b. Facade Length and Rhythm for Main Street

- i. Facades should be visually divided into a series of architectural bays that are derived, in general, from the building's structural bay spacing.
- ii. Architectural bays should align, in general, with individual or groups of storefronts and lobby entrances.

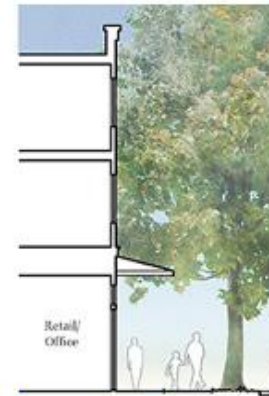

Figure 4: Zero Lot Line at the property line



Source: Cape Cod Commission. Cape Cod Multifamily Housing Design Guidelines. 2023 demonstrating the preferred method to visually divided massing and facades.

c. Massing Articulation

i. Bays or Oriel Windows¹

1. Bays or Oriel Windows are building components that are encouraged-required as a means to provide increased light, multi-direction views, and add architectural interest and variety to building facades.
2. Two bays can connect around corners to create distinctive living space or terminate in an important axis.

ii. Balconies are encouraged on building facades that face a public right-of-way so that residents can engage with the streetscape. Should balconies be proposed proper assurances should be in place to confirm all exterior items are properly secured.

iii. Disproportionately tall parapets and false-fronted gable ends are prohibited (Figure 6). Parapets may be integrated to screen mechanical or telecommunication equipment at an appropriate height as approved by the Hyannis Main Street Waterfront Historic Commission.

d. Roof Types

i. Pitched Roof ²

1. Pitched roofs such as gable, shed and hip roofs are frequently used on traditional buildings in the region. These are appropriate for use in the Districts. Vary the height of the roof line at both the roof peak and the eaves to break large roof masses into smaller elements and to vary their relationship to the ground. Incorporate several different roof forms on different parts of a large building, following historical examples.
2. When pitched roofs are used, submassings should be attached to the main massing at right angles, with either parallel roof lines or intersecting cross gables (Figure 5).

¹ Bay or Oriel Window dimensional standards are included in Table 12.B of §240-24.1.13.

² Roof pitch slope defined in §240-24.1.9 Section B.3.(h)

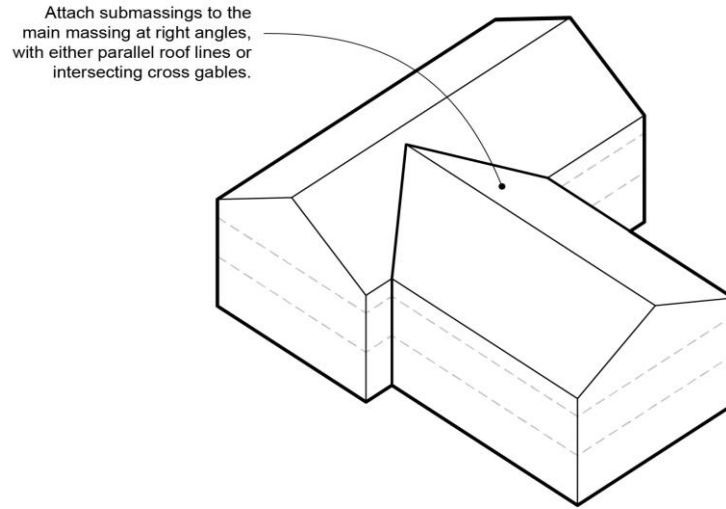

Figure 5: Example of a pitched roof submassing attached at a right angle.

3. Dormers³ may have a shed or pitched roof.
4. Non-functioning dormer windows, cupolas, and similar details are discouraged as they do not serve to break down the building mass, but instead give the impression of unrealistic appendages that detract from, rather than improve, the design.
5. Functioning dormers and architectural features are appropriate to establish variety between building submasses.

³ Dormer dimensional standards are included in Table 12.C.

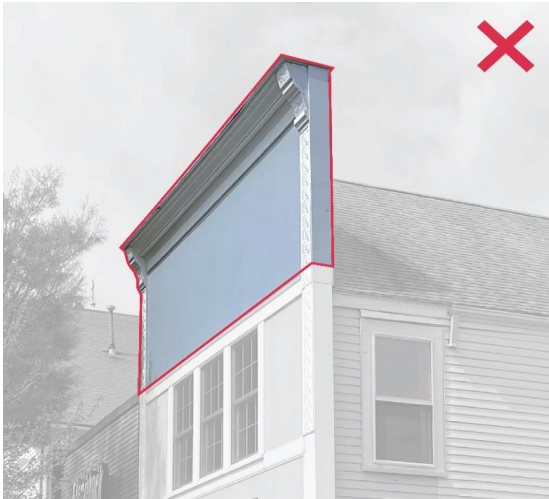

Figure 6: Example of a false front (a facade that extends above the roof line to form a tall parapet).



Figure 7: Green Roof recommendation for a flat roof

ii. Flat Roof

1. Flat roofs may be used on massings along Main Street as appropriate where existing development includes flat-roofed structures, or on some portions of a building as listed below.
2. Green roof options are encouraged as they provide many benefits including stormwater collection, reducing urban heat-island effect, and capturing pollutants.
3. Flat roofs are discouraged on primary massings outside of Main Street, but may be used on rear additions.

iii. Skylights, Vents, etc.

1. Skylights should not be located on the front roof plane.
2. Skylights should have a flat configuration and parallel to the roof plane. Bubble or other protruding skylight designs are prohibited.

iv. Chimneys

1. Chimneys should be composed of brick. Metal pipe is prohibited.

v. Photovoltaic (PV) Panels

1. If optimal solar orientation allows, place PV panels on the roof slope facing away from the front lot line so as to minimize the presence of solar panels from public view.
2. Organize PV panels into a consolidated array.
3. PV panels shall not negatively impact the historic character of the property ~~should match the roof color.~~ Panel skirting is required.
4. Mechanical equipment on low slope roofs should be consolidated to maximize PV area.

B. Facade Treatment

a. Materials

- i. The type and color of materials should be kept to a minimum, preferably three (3) or fewer (Figure 8). Breaking down the facades should be done in conjunction with changes in the roof, porches, bays and other major building components. It is not appropriate to mix masonry and wood cladding vertically in the same elevation.
- ii. Cedar shakes and clapboards are preferred materials for most exteriors. Facades can be painted, stained, or allowed to weather naturally. Brick is also acceptable. Stucco or Exterior Insulation and Finish Systems (EIFS) may be considered with thorough care of installation.
- iii. High quality composite siding as well as PVC composites may be acceptable for surfaces prone to weathering, rotting or excessive wear. **Gloss finishes are prohibited.**
- iv. Stone and brick are acceptable materials for commercial, civic, and institutional structures.
- v. For mixed-use buildings at least three (3) stories tall, the ground floor should be composed of a different material in order to create a visual break with the upper stories.
- vi. High-intensity, reflective, and metallic materials are prohibited.
- vii. Exposed concrete foundation walls should not be painted or faced with imitation materials.



Source: Cape Cod Commission. Cape Cod Multifamily Housing Design Guidelines. 2023



Figure 8: Example of a facade that uses only two materials, including cedar shakes

b. Color

- i. For building exterior walls, it is recommended that colors should be more subdued in hue intensity and light to medium value, as per the Nantucket Historic Commission color guidelines and in keeping with Cape Cod architectural precedent. See Appendix.
- ii. The palettes of historic colors and color guides for common architectural styles published by the group [Historic New England](#) are another helpful reference for appropriate use of color in the Districts.
- iii. Saturated colors within the approved color palette may be appropriate as used for doors, window sashes and/or shutters (Figure 9).



Figure 9: Example of a colorful door on a neutral facade in Beacon Hill, Boston

C. Fenestration⁴

a. Window Types

- i. Muntins on the outside are preferred (Figure 10).
- ii. Wood windows are strongly recommended.
- iii. Composite windows are permissible upon review.
- iv. Size and Shape of windows shall be of appropriate scale in relation to the proposed massing and the historic surroundings.

⁴ See Fenestration Standard in §240-24.1.5.A.7.



Figure 10: Example of two-over-two sash windows with an exterior muntin

- b. Doors
 - i. Residential front doors should be wood or simulated wood with a maximum of half lite exposure of glass.
 - ii. Doors to residential lobbies that face Main Street should follow the storefront/shopfront standards.
- c. Glazing
 - i. Glazing should be inset from the plane of exterior wall surfaces.
 - ii. Transparent glazing should be used, and highly reflective or dark-tinted glass are prohibited ~~should be avoided~~.⁵
 - 1. For ground story fenestration, glazing must have a minimum 60% Visible Light Transmittance (VLT) and no more than 15% Visible Light Reflectance (VLR) as indicated by the manufacturer.
 - 2. For upper story fenestration, glazing must have a minimum of 40% VLT and no more than 15% VLR as indicated by the manufacturer.

Formatted

⁵ See Visible Light Transmittance (VLT) requirements in §240-24.1.5.A.8.

D. Frontage Zones

a. Building Entrances

- i. Monotonous and repetitive storefront or lobby systems, awnings, canopies, sign types, colors, or designs ~~should~~ shall be ~~avoided~~ prohibited.
- ii. Storefronts and lobby entrances should include awnings or canopies to provide weather protection for pedestrians and reduce glare for storefront display areas.
- iii. Lobby entrances for upper story uses should be optimally located, well defined, clearly visible, and separate from the entrance for other ground story uses.
- iv. Lobbies should be limited in both width and total area to preserve floor space and frontage for other ground story uses. Buildings should use any combination of facade articulation, a double-height ceiling, a distinctive doorway, a change in wall material, a change in paving material within the frontage area, or some other architectural element(s) to make lobbies visual and materially distinctive.
- v. Orient both retail and residential entries to face public streets and sidewalks.

b. Frontage Types⁶

i. Shop Fronts

1. Awnings/Canopies

- a. Retractable and roll-down awnings are encouraged.
- b. Awnings and canopies should be solid colored or striped.
- c. Awnings should be made of canvas.

2. Window Display

- a. Storefront windows should use transparent glazing and avoid the use of dark tinted glass or highly reflective glass which shall be prohibited.
- b. Metallic and clear anodized aluminum framing is prohibited on storefront windows and doors. Darker aluminum versions may be considered (Figure 11).
- c. Illuminated storefront windows and streetscape lighting help create an appropriately scaled pedestrian environment

⁶ See Table 11 in the Downtown Hyannis Zoning



Figure 11: Example of an aluminum storefront systems
 Source: Nantucket shopping guide and Portland, Maine shopping guide

- ii. For residential uses, appropriate frontage types⁷ include:
 1. Common Lobby
 2. Entry Plaza
 3. Front Garden
 4. Dooryard or Stoop
 5. Porch
- iii. For mixed uses, appropriate frontage types⁸ include:
 1. Gallery
 2. Storefront
 3. Common Lobby
 4. Dining Patio
 5. Entry Plaza

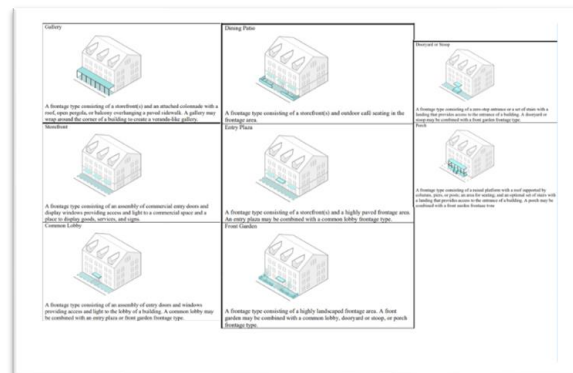

Frontage Types Downtown Hyannis Zoning (See Appendix D)

⁷ See Table 11 in the Downtown Hyannis Zoning or Appendix D

⁸ See Table 11 in the Downtown Hyannis Zoning or Appendix D

E. Façade Amenities and Lighting

- a. Exterior up and down lighting is preferred.
- b. Internally lit signage is prohibited.
- c. Historic-style acorn, onion light, or lantern style light fixtures are encouraged. Lighting styles that complement the existing fixtures on Main Street are also acceptable (Figure 12).



Figure 12: Examples of desirable light fixture

F. Renovation and Repair

- a. Repair and renovate is a preferred option over rebuild.
- b. Façade Treatment
 - i. Maintain and restore original siding on historically significant structures when possible. If siding must be replaced, the original design should be replicated with authentic materials. The use of modern material substitutes may be permissible pending HHDC review.
 - ii. Masonry that has not been painted in the past should not be painted without review by the HHDC.
 - iii. Stucco-coating a historic building is typically not an appropriate treatment if it has not been previously stuccoed. **Applicant should consider restoration of the elevation to the original treatment.**

- iv. Colors historically appropriate for the age and style of the structure are recommended. Generally, historic color schemes often utilized only two or three colors. The palettes of historic colors and color guides for common architectural styles published by the group Historic New England are another helpful reference for appropriate use of color in the District.
 - v. Avoid painting surfaces that have never been painted, including stone lintels, sills and masonry. **These architectural exterior changes shall be reviewed and approved first by the Commission, if within the District.**
- c. Fenestration
- i. Avoid blocking, reducing, or changing any original and appropriate pattern of windows when renovating older buildings.
 - ii. Storm windows may be used to improve the energy efficiency of older windows. **Storm windows shall be white unless alternative historic options provided for consideration.**
 - iii. Preserve original window features as much as possible.

Site Plan Design Regulations and Guidelines

III. Parking Design Regulations

- A. Surface Lot Parking (Figure 14)
 - a. Parking lots in new development projects should be located to the rear of structures at the interior of a block. No parking area shall be designed such that parking is within the required front yard setback.
- B. Vehicular Access⁹ (Figure 14)
 - a. Access to parking lots and structures parallel to the Front Elevation is prohibited when access along another lot line is available.
- C. Loading Zones and Service Areas
 - a. Access to loading docks and areas parallel to the Frontage Elevation are prohibited.
 - b. Outdoor service areas are not permitted along any Frontage Elevation.
 - c. Trash collection, trash compaction, recycling collection and other similar service areas must be fully enclosed within a building or located to the side or rear of buildings and fully screened with fencing or landscaping.
- D. Vegetation¹⁰
 - a. Break up large parking lots (e.g. lots greater than 20 parking spaces) by incorporating planting islands landscaped with native shade trees and shrubs. The landscaping shall adequately screen parking lots from public frontage. [See Appendix C for native planting list.](#)
- E. Lighting¹¹
 - a. All parking area lighting shall be dark-sky compliant.
 - b. Lighting should be scaled to complement the pedestrian character of the District. Light fixtures should be no higher than 15 feet from grade. Surrounding land uses will be considered when determining appropriate pole height. In no case should the total height of the light fixture exceed 20 feet.

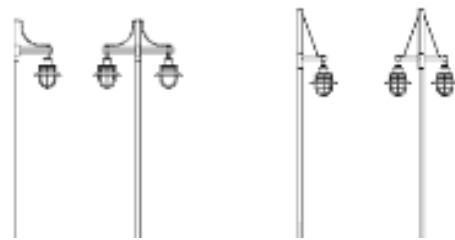

Figure 13: Example of appropriate parking lot lighting with historic qualities

⁹ See §240-24.1.5.D.7.

¹⁰ See §240-24.1.5.E.3.

¹¹ See §240-24.1.5.D.5.

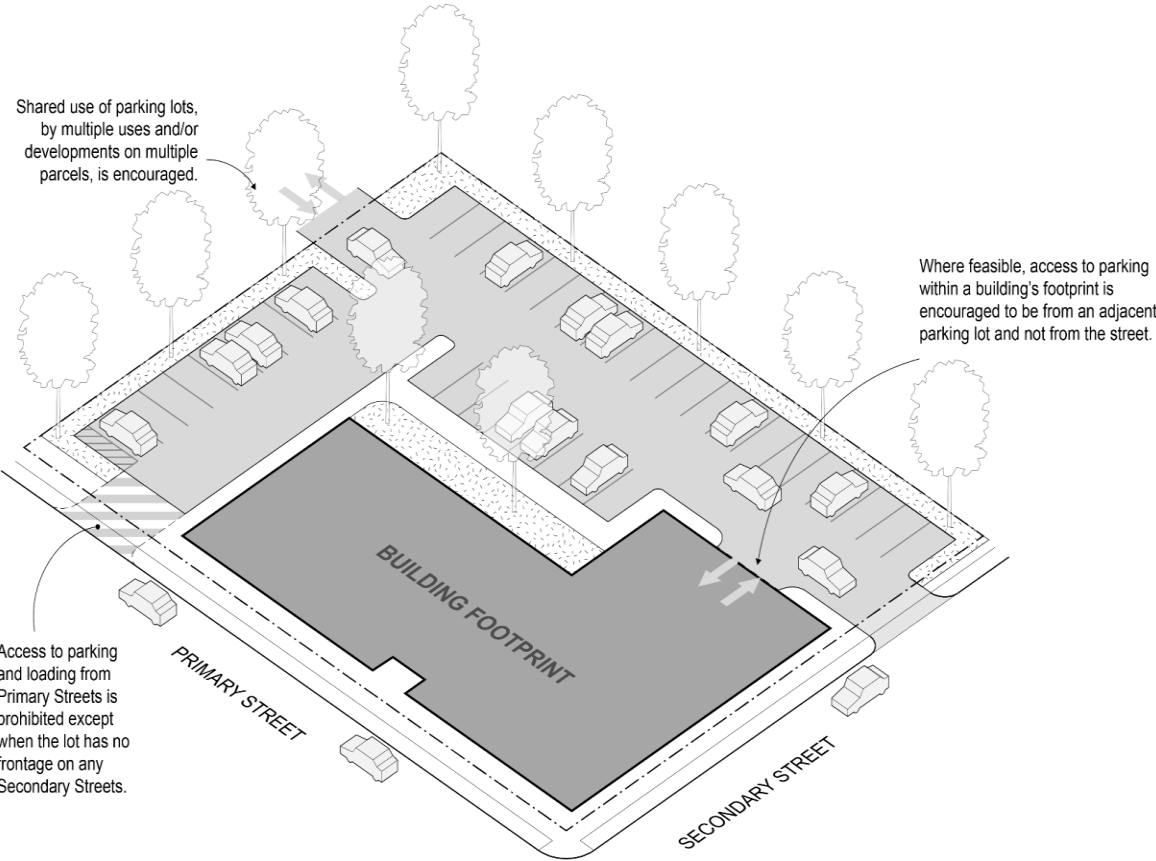

Figure 14: Parking design regulations

IV. Parking Design Guidelines

A. Surface Lot Parking¹²

a. Location¹³

- i. To the extent possible, parking areas shall be shared with adjacent businesses. Adjacent sites should link internal vehicular circulation.
- ii. Where parking areas are adjacent to street frontages, extensive landscape buffering of the parking area is required (Figure 15 and 16).¹⁴ [See Appendix C for native planting list.](#)



Figure 15: Example of inadequate landscape buffering



Figure 16: Example of adequate landscape buffering

¹² See Surface Parking Lot Design Standards in §240-24.1.5.E.

¹³ See Parking Location in §240-24.1.5.C.3.

¹⁴ See Surface Parking Lot Design Standards in §240-24.1.5.E.3.

B. Vehicular Access¹⁵

- a. New curb cuts on existing public ways shall be minimized.
- b. To the extent feasible, access to businesses shall be provided through one of the following methods: through a common driveway serving adjacent lots or premises, or through an existing side or rear street.

C. Loading Zones and Service Areas

- a. Outdoor loading facilities, including all docks and areas used for the storage, staging of goods or materials, and trash and recycle pickup that are visible from a public street, public space, or abutting properties in any Residential Districts must be screened from view. These facilities should be located at the rear of the property and away from neighboring residential properties as is possible.
- b. Outdoor service areas that are visible from a public street, public space, or abutting properties in any residential districts must be fully screened from view.
- c. Interior loading must be screened from view by solid, non-transparent doors which must remain closed when the loading dock is not in use.

D. Paving Materials

- a. Design parking lots for average, not peak, volume and encourage the use of permeable or pervious paving wherever possible. Handicapped spaces should use asphalt to maintain accessibility standards.
- b. For lightly used or seasonal parking areas, use pervious materials such as grid blocks with grass, crushed shells or crushed stone (Figure 17).
- c. Consider the use of traditional materials like crushed shell, crushed stone, or gravel for single family residential driveways.
- d. Incorporate pedestrian pathways or raised sidewalks and distinguish pedestrian pathways by changing the paving material, texture, or color.

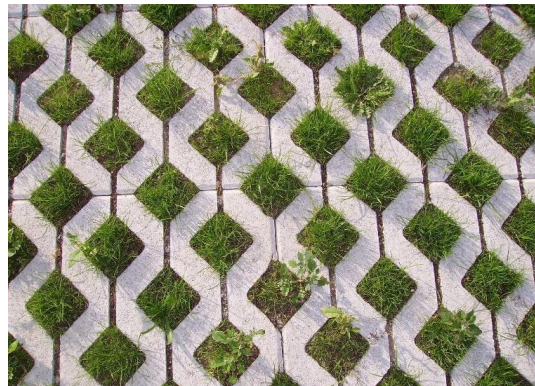

Figure 17: Example of pervious materials for parking lots

¹⁵ See §240-24.1.5.D.7.

E. Vegetation¹⁶

- a. Design parking lots with attractive native landscapes (Figure 18).
- b. Landscaped contours are recommended to visually screen parking areas and prevent glare of headlights.
- c. Landscape areas must be planted with native trees and shrubs and must comply with zoning. Refer to capecodnativeplants.org for native vegetation recommendations.

F. Lighting¹⁷

- a. All outdoor lighting must be directed downward and shall remain on site.
- b. Parking areas should be screened from neighboring properties to prevent spillover of site or vehicular lighting. Dense year-round plantings are recommended. [See Appendix C for native planting list.](#)
- c. Parking lot light fixtures should be located within landscape setbacks or parking lot islands.

G. Structured Parking

- a. Multi-level parking structures can minimize the amount of impervious surface areas and reduce parking area footprint.
- b. Multi-story parking structures are preferably located to the rear of a building.
- c. If parking structures will be visible from the street or public ways, they should be incorporated into the design of the building, with a similar level of architectural detail.

H. Solar Canopy

- a. Solar canopy systems over parking areas are highly discouraged. If proposed, systems shall be installed to limit visibility of the system from the public way.

I. Bicycle Parking

- a. Parking areas shall include provisions for safe and lockable bicycle parking in locations that are safely segregated from vehicular traffic and parking areas.



Figure 18: Example of attractive landscape design in parking lot

¹⁶ See §240-24.1.5.E.3.

¹⁷ See §240-24.1.5.D.5.

V. Site Amenities and Landscape Design Regulations

A. Pedestrian Walkways and Sidewalks

- a. Primary walkways linking site features shall be a minimum of 5 feet wide. Preferably wider where space allows.
- b. Enliven and activate the public realm by expanding the publicly accessible private spaces along the sidewalk, in association with the creation of retail, cultural and office space. Active ground level spaces should have strong, interactive connections with adjacent public sidewalk/plaza space using strategies such as extensive transparent glazing, ~~interactive media or~~ public art, large operable doors and windows, extensive outdoor lighting, or associated outdoor seating **as approved by the Commission, if in the District.**
- c. For new development, one street tree for every 20 to 30 linear feet of frontage shall be required. Street trees shall be between 2.5 and 4 inch caliper and properly installed per Town Department of Public Works requirements.

B. Outbuildings and Garages

- a. All outbuildings and garages shall be located to the rear of structures at the interior of a block or properly screened so not to be visible from the frontage. No outbuildings or garages shall be located within the required front yard setback.

VI. Site Amenities and Landscape Design Guidelines

A. Vegetation¹⁸

- a. Lot areas not covered by structures or impermeable surfaces should be Landscape Areas, as defined:
 - i. Landscape Area. The area of a lot covered by any combination of trees, shrubs, perennials, grass or horticultural elements, decorative stonework, pavers, screening, or other landscape architectural elements, all of which are designed to absorb and filter stormwater runoff, enhance the visual amenity of a property, and/or to provide an amenity for common use by the occupants of a building.
- b. Whenever possible, retain existing vegetation and preserve the natural landscape, especially mature trees. **Clear cutting of a parcel is not acceptable.**
- c. Use plant materials that are tolerant to the Cape's environmental conditions. Emphasis should be placed on the use of native, pollinator and low-water use plants (Figure 19). [See Appendix C for native planting list.](#)

¹⁸ See Landscaping in §240-24.1.5.D.2.



Figure 19: Examples of native and low-water use plants (top-left: wild sundial lupine, top-right: baptisia, bottom-left: hypericum, bottom-right: little bluestem native grass).
Source: capecodnativeplants.org



Figure 20: Native clover lawn
Source: capecodnativeplants.org

- d. Minimize lawn area, as most lawn grasses require supplemental irrigation and regular applications of fertilizer to stay green. Native clover lawn is a great alternative (Figure 20). The use of artificial turf is not allowed.
- e. Low-Impact-Development practices consistent with state law, such as rain gardens and bioswales, should be installed to treat and infiltrate runoff from parking lots, thoroughfares, entry plazas, dining patios, and other impervious surfaces (Figure 21).
- f. Spacing of trees vary with type, but 20 to 30 feet should generally apply for street trees.
- g. Deciduous native shade trees should be used along the south side of buildings to shade and cool in the summer but allow sun to passively warm the building in the winter.
- h. Native shade trees should be used throughout paved areas and along pedestrian paths to provide shade and reduce heat buildup and glare.



Figure 21: Bioswale

- i. Do not plant trees on steep embankments as soil erosion may cause instability and uprooting. Use grasses, groundcovers and low shrubs instead.
- j. Proper maintenance and timely replacement of dead or deteriorating plant material is required.
- k. Incorporate landscaping, including street trees, in the design of storefront areas. Frontage design and signage locations shall be coordinated with the placement of plant material.
- l. Use pedestrian-oriented landscape areas adjacent to the building to add variety and depth to a large building facade. Incorporate landscaped areas within large projections or setbacks in the facade to provide relief and visual interest, while also softening the building exterior and mass (Figure 22).

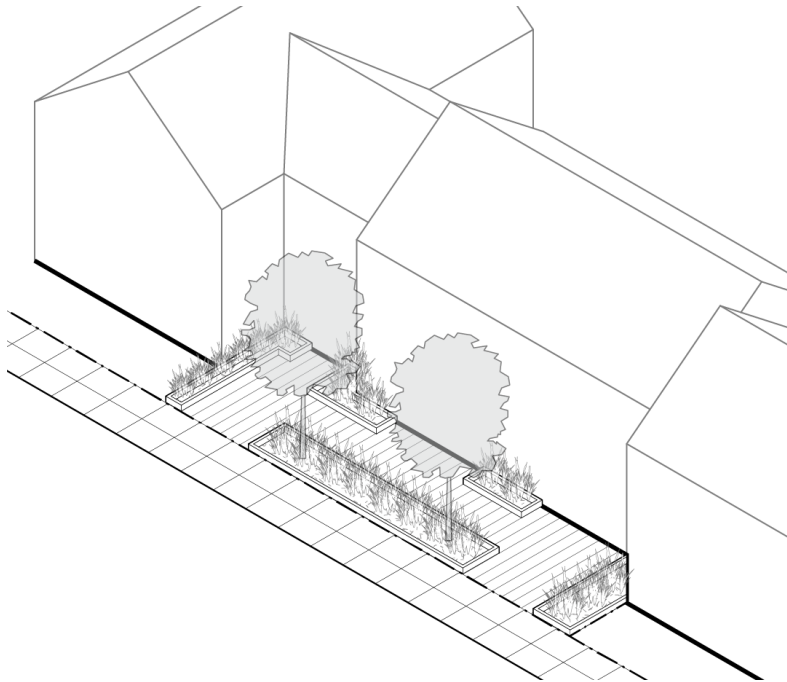

Figure 22: Example of a planting zone to add variety and depth to a large building facade

B. Pedestrian Walkways and Sidewalks

- a. The width of the sidewalk should be calibrated to the height of the adjacent building as well as the width of the street. Wider sidewalks are appropriate for multi-lane streets with commercial activity, while smaller sidewalks are appropriate for residential and neighborhood streets. Five foot minimum is required.
- b. Sidewalks and public walkways should be fully accessible, with paved, level surfaces to facilitate movement for persons with disabilities.

C. Lighting

- a. Decorative, historic-style light fixtures are recommended within the Districts. Acorn or lantern style luminaires are recommended. Lighting styles that complement the existing fixtures on Main Street are also acceptable.
- b. Night lighting illuminating pedestrian walkways is encouraged.

D. Fences/Screening

- a. Fences¹⁹
 - i. Keep high fencing at the rear of the property, with lower fences near the front of the lot.
 - ii. Traditional forms are required in fence construction. Appropriate historic designs include picket, post and rail, and some simple iron fencing.
 - iii. Wood fences can be left to weather or painted white.
 - iv. Always place the premium side of the fence toward the street. The structural posts and stringers should be on the inside of the property.
 - v. Wrought iron fencing is appropriate and related iron gates should be painted black.
 - vi. Stone/rock walls are allowed if they have the appropriate character for the Cape Cod landscape.
- b. Screening
 - i. Landscape berms with dense native vegetation can be used to provide screening.
 - ii. Where site topography is suitable, structures may be partially built into a slope or hillside to reduce their apparent bulk and to limit views from certain vantage points.
 - iii. A landscape buffer strip shall be provided to screen commercial uses from residential areas. This buffer strip shall be planted with a combination of native grasses, shrubs, and trees and will also service as a rain garden.

¹⁹ See §240-24.1.5.D.6.

VII. General Site and Placemaking Guidelines

- A. Incorporate site context in the design of public spaces
 - a. Reinforce and integrate new public space into the public realm
 - ~~b. Consider and respond to adjacent building entrances, unique building forms and/or landscape masses. Buildings facing public spaces should be inviting to pedestrians with entrances, windows, and active uses at the ground floor. *Where elevations lack these features, such as at blank walls and at garages, consider incorporating public art features such as colorful murals to provide pedestrian interest as approved by the Commission, if in the District.*~~

- B. Celebrate and incorporate community identity
 - a. Where appropriate, consider special signage or branding that reflects the historic, cultural or natural character of the community. ~~Provide opportunities for interpretation of unique community features such as historic, artistic, or environmental elements.~~
 - b. Integrate public art into the designs of parks or public spaces and its surroundings. Art can be a featured piece, or part of the architectural elements of the spaces such as the paving or a paving feature, the light poles, an interactive water feature, furnishings, signage and/or an element of the adjacent or surrounding landscape or architecture. Artwork should be designed by an artist, who *may* engage the community in the design process **as approved by the Commission, if in the District.**
 - ~~c. Consider interactive design solutions to enhance the relationship between people and elements of the natural and built environment.~~
 - d. Reuse or renovate existing historic or cultural features where feasible in or adjacent public spaces.
 - e. Support and prioritize local community art and artists that emphasis historic and maritime character.**

- C. Make public spaces inviting
 - a. Frame public spaces and/or pathways with landscape, trees (Figure 23) and/or light fixtures (Figure 24) to define the spaces, and create edges to establish a transition from space to space.



Figure 23: Landscapes in public spaces
Image: Plantusnyc.com: Bryant Park/Hines



Figure 24: Light fixtures in public spaces
Source: Congress for New Urbanism

Integrate public spaces with sidewalks, streets and alleys, circulation routes, recessed entries, courtyards, plazas, through block connections.

b. Furnishings:

- i. **Seating and Tables:** provide a variety of arrangements using comfortable and durable materials that are accessible to all ages and abilities. Permanent seating should be located at the edge of spaces and along connecting pathways where desired.
- ii. **Trash and Recycle Bins:** place in strategic locations with convenient access for collection and maintenance.
- iii. **Bike Racks:** locate adjacent to building entries, near shared parking areas and/or next to play areas. Design bike racks to be attractive, playful historic and functional as approved by the Commission (Figure 25, 26).



Figure 25: Attractive and playful bike racks Source: Congress for New Urbanism

Commented [JK3]: Remove picture



Figure 26: Attractive and playful bike racks
Source: Congress for New Urbanism

Provide adequate lighting to highlight the public space as community focal points and to highlight special buildings and features throughout the day and evening. Consider seasonal lighting and provide adequate light levels to support pedestrian safety and security at central spaces pathways, and crosswalks at night. Light levels and the direction of lighting should maximize safety yet minimize night sky light pollution in the surrounding neighborhood.

- c. Provide ample space for pedestrian flow and circulation, especially in areas where there is already heavy pedestrian traffic or where the project is expected to increase pedestrian traffic.
- d. Design access points with distinguished features so all visitors can be greeted and welcomed through a “front door/gateway”
- e. Provide clear and creative wayfinding signage to connect different spaces.



Hyannis Main Street, 2020

Commented [JK4]: Remove picture

Sign Regulations and Guidelines

VIII. Sign Design Regulations



Figure 27: Illustration of permitted signs in pedestrian-centric areas, including wall signs, window signs, A-frame signs, blade signs, awning signs, and neon signs.

v

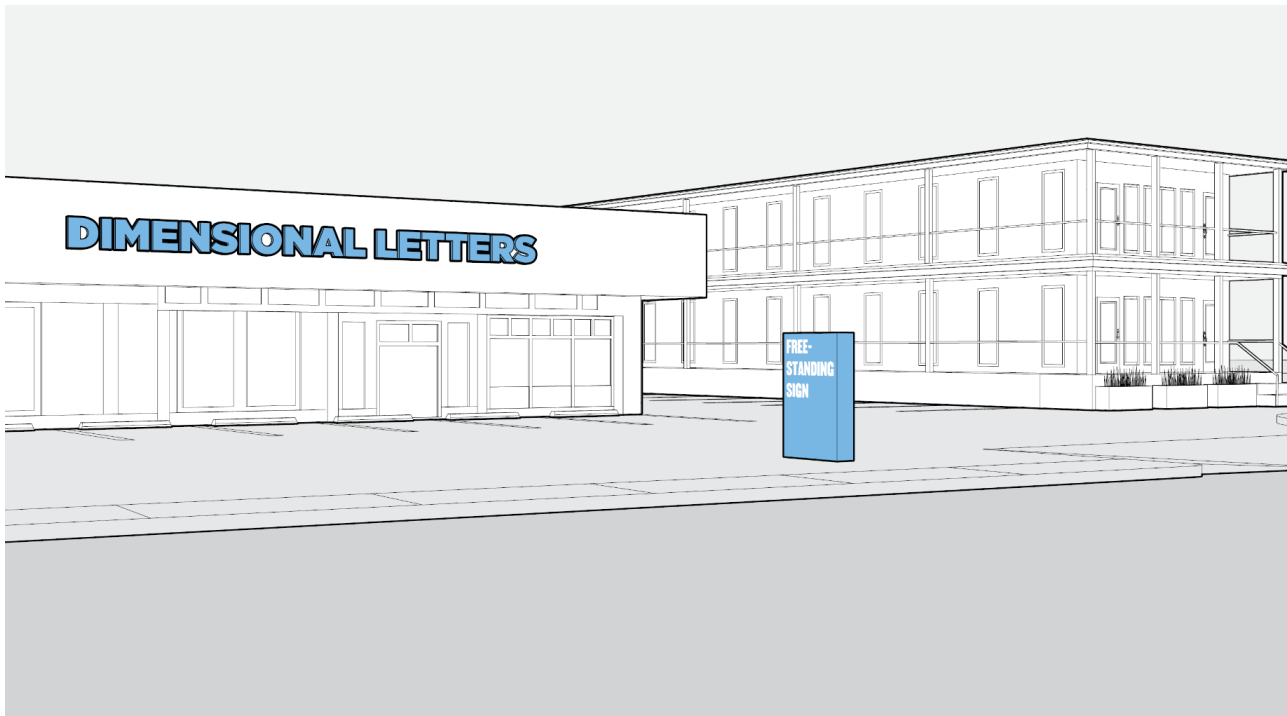

Figure 28: Illustration of permitted signs in vehicle-centric areas, including free-standing signs and dimensional lettering directly mounted on the building.

- A. All signs are to be three dimensional wood or PVC unless waived by the Commission.
- B. Each property shall be limited to one freestanding sign. All sign dimensions must comply with zoning.
- C. Wall signs shall be mounted directly on the sign fascia or by bracket, when available.



Figure 29: PVC and wood frame, Nantucket, MA

D. The following sign types are prohibited in Downtown Hyannis:

- Internally illuminated signs
- Signs made of plastic or vinyl
- Simulated neon signs
- Flashing, blinking, scrolling, or video signs or displays. Neon signs shall not flash or blink.
- Cabinet or box signs
- Molded plastic A-Frame signs
- Flat banner signs
- Handwritten signs and displays
- Open signs when the applicable business is not open.



Figure 30: Lightbox - internally illuminated



Figure 31: LED examples

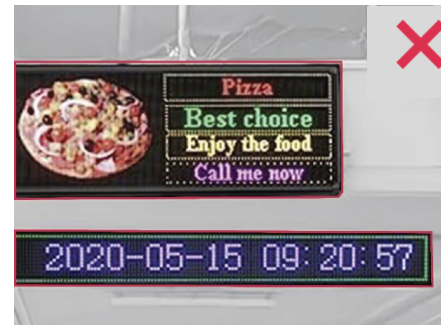

Figure 32: Flashing, blinking, scrolling, video



Figure 33: Flashing, blinking, scrolling, video



Figure 34: **Prohibited Sign Designs** - Illustration of prohibited signs in pedestrian-centric areas, including internally luminated signs, simulated neon signs, box signs, and molded plastic A-frame signs.



Figure 35: Flat banner signs are prohibited.

IX. Sign Design Guidelines

A. Sign Type & Placement

- a. Signage should be designed to be visible by both pedestrian and vehicle traffic.
- b. Signs on the fascia or awnings are best for vehicular traffic and signs under canopies or on windows or doors are best for pedestrian traffic. Freestanding signs may be appropriate where the building is set back from the street.
- c. Signs should be sized and placed to reinforce the architectural elements of a façade. Where present, utilize the sign fascia (Figure 36).
- d. Signs should not obscure windows or architectural details such as decorative trim, pilasters, or transom glass (Figure 37,38,39).



Figure 36: Sign fascia utilization on a façade

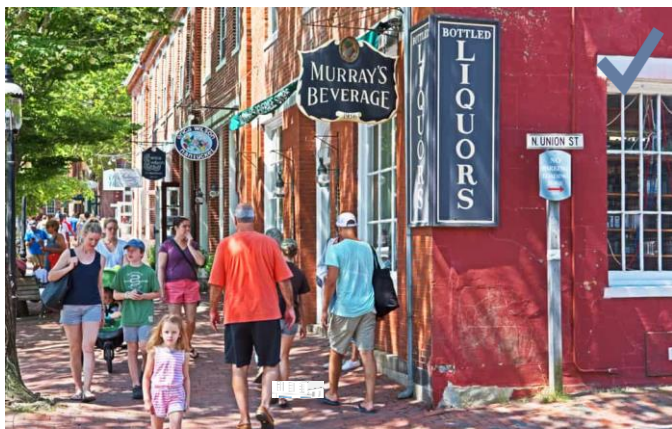

Figure 37: Architectural use of space for signage: Nantucket shopping

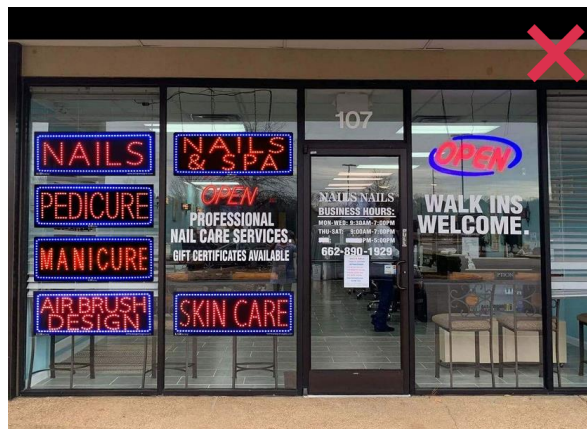

Figure 38: Example of signage that obscures windows and architectural features



Figure 39: Excellent, discreet example of signage on historic pillar facade



Figure 40: Example of wall sign that showcase a business' unique character

Source: <https://www.frontsigns.com/products/outdoor-signs/>

B. Wall Signs

- a. Wall-mounted signs in traditional styles and colors are appropriate.
- b. Wall signs that showcase a business' unique character are also appropriate (Figure 40).
- c. Individual letters mounted directly on the building are recommended, especially where the building has a sign fascia.
- d. Individual letters mounted on a visible track or "raceway" are not appropriate (Figure 42).
- e. Individual letters mounted directly to the façade may be back-lit or halo-lit as determined by the Commission, depending on the type and color of the illumination proposed.



Figure 41: Wall-mounted signs in traditional styles and colors are appropriate.



Figure 43: Individual letters mounted directly on the building are recommended, especially where the building has a sign fascia.



Figure 42: Example of wall sign that is inappropriately mounted on a track and not recommended.



Figure 44: Example of wall sign that is appropriately mounted on the building.

C. Projecting Signs

- a. Projecting signs are encouraged in the districts. Projecting signs have been shown to be effective in drawing the attention of pedestrians.
- b. Mounting hardware should be attractive and an integral part of the overall design of the sign (Figure 46).

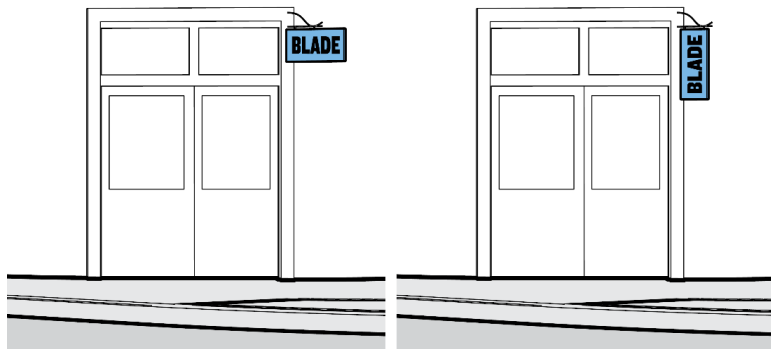

Figure 45: Projecting signs with attractive mounting hardware are encouraged.

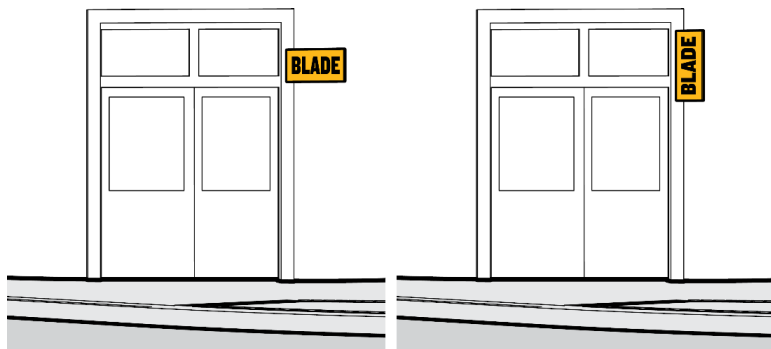

Figure 47: Projecting signs without mounting hardware are not recommended.



Figure 46: Example of a great hardware projecting sign

Source: Fit Small Business.com

D. Freestanding Signs

- a. Freestanding signs are appropriate where business entrances are set back from the street (Figure 48).
- b. Low-profile native landscaping around the base of the sign is encouraged.
- c. Multiple tenants names on a single sign should be a coordinated set of signs in size, style, and background color (Figure 50).

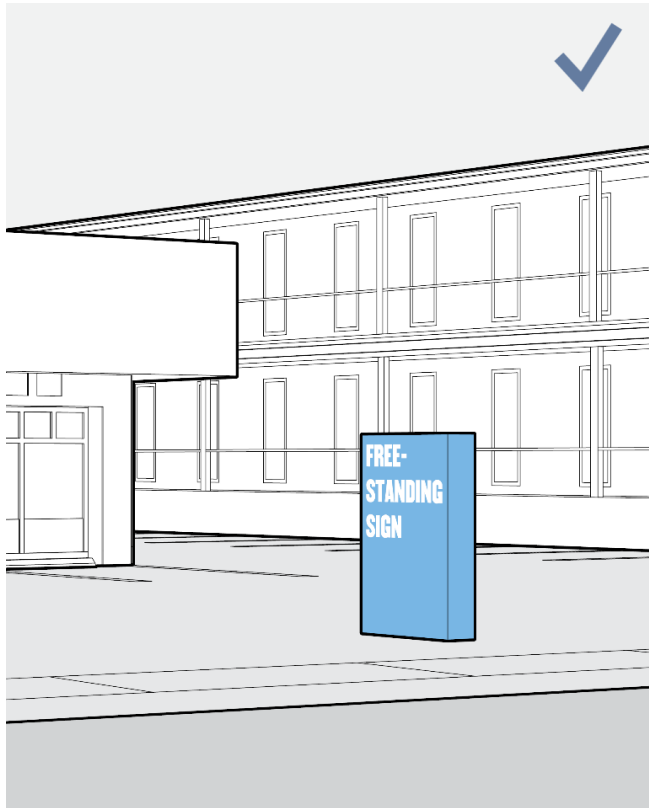

Figure 48: Where businesses are set back from the street, freestanding signs are allowed.



Figure 49: Where businesses are not set back from the street, freestanding signs are discouraged.



Figure 50: Example of multi-tenant signage, Chatham, MA
Source: www.familytravelmagazine.com/
in Thomasville GA



Figure 51: Example of uncoordinated sizes of tenant names on a sign

E. Under Canopy Signs

- a. Signs hanging under a canopy are encouraged (Figure 53).
- b. In a multi-tenant building, hanging signs should be similar in size, style, color, and hardware (Figure 53).



Figure 52 and 53: Example of consistent sign sizes in multi-tenant building
Source: visitedgartown.org/shopping and Capecod.com/Mashpee Commons

F. Window Signs

- a. Signs painted directly on windows or doors are encouraged.
- b. Etched, painted, or gold-leaf letters are recommended. Vinyl letters may be considered.
- c. Window films, graphics, neon painted signs, or other signs that obscure the transparency of windows are prohibited (Figure 55).



Figure 54: Signs should not obscure the transparency of windows.



Figure 55: Signs that obscure the transparency of windows are discouraged.



Figure 56: Example of window lettering
Source: visitedgartown.org/shopping

G. Awning Signs

- a. Awning signs are appropriate and encouraged.
- b. Lettering is encouraged to be located on the front flap of the awning, as opposed to the top sloped awning surface (Figure 57).



Figure 57: Awning signs with lettering located on the front flap of the awnings are encouraged.

H. Open/Closed Signs

- a. Open/closed signs must be located at the public entrance to the business, or displayed in a window or door
- b. Neon open signs may be permitted; neon signs should be red or red and blue.
- c. LED signs, simulated neon, or fluorescent inks are prohibited.
- d. All electronic open/closed signs shall be turned off at the close of business.



Figure 58: Non-simulated



Figure 59: Neon open signs may be permitted; neon signs should be red or red and blue.



Figure 60: Simulated neon signs are prohibited.

I. A-Frame Signs

- a. Signs must be made of wood, metal, or other quality materials. (Figure 63).
- b. When used, chalkboards should be black and incorporate professional lettering.
- c. All A-Frames shall be removed from a public way at close of business.

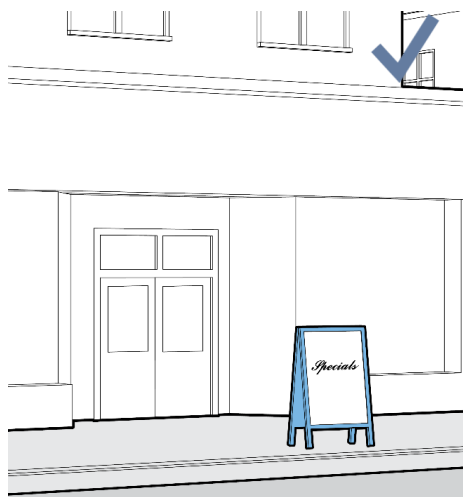

Figure 61: A-Frame Signs must be made of wood, metal, or other quality material.



Figure 62: Molded plastic A-Frame signs are prohibited.



Figure 63: Example of A-Frame Wood Sign with Black Chalkboard

J. Trade Flags

- a. Trade flags must be attached at the primary public entrance to the business and shall not be larger than 3'x5'
- b. Trade flags are encouraged to display images representative of the business or service offered.
- c. Trade flag colors are encouraged to be unique to business' theme or logo.
- d. All trade flags shall be removed from a public way at close of business.

K. Trade Figures or Symbols

- a. A trade figure or symbol should be representative of the business and/or its services and, where applicable, based on historic trade representations.
- b. Trade figures or symbols must be located on private property and brought in at closing.
- c. Figures must be made of wood, metal, or other quality materials. Plastic is not appropriate. Inflatable displays are prohibited

L. Materials

- a. Carved or sandblasted signs made of wood are recommended. PVC composites, medium density overlay plywood or HDPE sign board may also be appropriate.
- b. Hand-painted signs are encouraged.
- c. Aluminum or metal signage is discouraged but may be appropriate in some locations as determined by the Commission.
- d. Neon signs may be appropriate as determined by the Commission. Neon signs must be made of traditional, gas filled tubes.

M. Colors, Text and Design

- a. The colors used on signs and graphics should complement the building and its trim colors.
- b. The content of signs should be clear and legible. Lettering should be simple and fonts should be easily read.
- c. Only one or two fonts should be used on a sign. Avoid script fonts, as they can be hard to read.
- d. Consider the proportion of the text and logo to the overall size of the sign. Text should not appear crowded on the sign or be too small to read easily.
- e. Text should be kept to a minimum to make signs easier to read. Lists of products or services are not generally appropriate for primary business identification signs.
- f. Signs with a dark background color are often more noticeable.
- g. A border around the edge of the sign can help a sign stand out.
- h. Websites and phone numbers are prohibited ~~strongly discouraged on signs.~~

Appendix A

Allowable Paint Colors

Main Street Yellow (doors) - PMS 120



Cottage Red (doors and shutters) - PMS 492



Hamilton Blue (siding/shingles, doors and shutters) - PMS 5415



Cobblestone (siding/shingles) - PMS 403



Nantucket Blue (doors, shutters) - PMS 5473



Quaker Gray (siding/shingles, doors and shutters) - PMS 423



Chrome Green (doors and shutters) - PMS 3302



Nantucket Gray (siding/shingles, doors and shutters) - PMS 416



Essex Green (doors and shutters) - PMS 5605



Nantucket Red (doors) - PMS 1807



Newport Blue (siding/shingles, doors and shutters) - PMS 5408



In addition to these colors, different shades of white can be used for the body of buildings, trim and sash, and different shades of black can be used for shutters, windows and doors.

APPENDIX B Native Plant List

Native List: Town of Barnstable
 Alice Marcus Krieg, August 12, 2024

NOTE: this plant list is used for guiding purposes only, There are varietal and numerous species not listed here that are equally suitable. Please consult local and state native plant organizations, garden centers and trusted horticulturalists for recommendations. The aim of this list is to set the stage for native and trusted plant species to encourage pollinators, clean water filtration habitats and soil stabilization. Diversity within planting palettes is recommended to avoid monoculture and infestation damages.

TREES

Latin	Common	Suggested Variety	Mature Height	Attribute
Acer Rubrum	Red Maple		btw 40 to 70'	brilliant fall foliage that turns yellow or orange, large species tree
Betula populifolia	Grey Birch		30'	smaller variety birch tree, fast growing, excellent color in Fall, much color and interest in bark
Carpinus caroliniana	American Hornbeam		20-30'	large specimen tree, there is a narrow upright variety as well, excellent fall color
Castanea dentata	American Chestnut		100'	nut, early variety, almost extinct due to blight, making its way back into landscape
Cercis canadensis	Eastern Redbud		20-30'	early color, brilliant pink/purple
Chamaecyparis thyoides	Atlantic white cedar		30-50'	evergreen columnar shape
Cornus florida	Appalachian Dogwood		15 - 25'	Spring flowering, great medium height tree
Juniperis communis	shrub and tree varieties		2 - 50'	evergreen, shrub and tree varieties
Juniperis virginiana	Eastern red cedar		30 - 90'	evergreen, conical shape, resistant to heat, cold and drought
Malus coronaria	Crabapple		15-20'	early color, edible fruit
Nyssa sylvatica	Tupelo, Black Gum		btw 60 - 80'	good for wet conditions, great fall color
Pinus strobus	Eastern White pine		up to 200'	evergreen, globular shape, full sun
Platanus occidentalis	American sycamore		75-100'	large stately, specimen tree, hardwood tree
Prunus americana	American wild plum, red to yellow fruit	Marshalls Plum	8-20'	edible fruit, full sun and partial shade
Prunus maritima	Beach plum, blue to black fruit		6-15'	fruiting and edible, Spring flowering, great for dune locations
Quercus alba	White Oak		btw 60 - 100'	large timber tree species, red foliage in fall
Quercus coccinea	Scarlet Oak		50-70'	Red oak type tree, full sun and dry acidic soils
Quercus paulstris	Pin Oak, swamp oak		70-90'	full sun, wet soils, tolerates poor drainage
Quercus rubrum	Red Oak		btw 60 to 80'	wide adaptability to conditions, large timber species, great fall color
Tilia americana	Basswood, Linden		40-70'	very fragrant, June bloom, full sun to part shade, great for urban sites
Sassafras albidum	Cinnamon wood, Smelling stick, Black ash		60'	April - May flowers, edible, fruits in August - October, full sun is best

SHRUBS

Amelachier Canadensis	Serviceberry, Shad		10-18'	early spring color, fall color, edible berries, shrub and tree varieties
Aronia - 3 varieties avail	Chokecherry: black, purple and red		3 - 10'	great fall foliage color, great for hot, sunny, dry locations
Comptonia peregrina	Sweet fern		2-5'	sweet fragrance, blooms May - august. Low water use, sandy soils
Clethra alnifolia	Sweetpire, Summersweet, Sweet Pepper	Merlot, Henry's Garnet	4 - 8'	fragrant, deciduous, shade conditions, sandy soils best
Hamamelis virginiana	Witchhazel		12-20'	early blooming, medicinal
Hydrangea arborescens	American hydrangea, smooth	Annabelle, Haas Halo	4 - 6'	June through Oct bloom, low maintenance shrub
Hydrangea quercifolia	Oakleaf hydrangea	Alice	4 - 6'	panicle variety hydrangea, excellent fall color
Ilex glabra	inkberry	Densa, Shamrock	3 - 12'	somewhat evergreen, fall berries, great medium size shrub
Kalmia angustifolia	American laurel, mountain laurel	Poke Logan, Hoffman's Pink	5 - 15'	June flowering, evergreen, great backdrop shrub
Morella/Myrica	bayberry		10-15'	fragrant, waxy green leaf, deciduous, grows on sand dunes, bayberry candle source
Physocarpus opulifolius	common ninebark		5 to 10'	full sun to light shade, drought tolerant once established
Rhododendron	great laurel, many varieties		5 to 40'	evergreen, large & small varieties, incl azalea, Spring flowers, sun/shade conditions
Rhus glabra, typhina	sumac	Grow Low	15 - 30'	great fall color, pollinator
Rubus odoratus	flowering raspberry		3 to 6'	edible, thorny, Flowers in spring, fruits in summer through fall
Sambucus Canadensis	elderberry, black or red		5-8'	edible berries, blooms early summer, full sun thorny,
Spiraea alba	meadowsweet	Kim's knee high, Bridal Veil false spirea	2 to 10'	Great foliage color, blooms in early Spring, Full sun
Spiraea tomentosa	steepiebush		4 to 5'	smaller height, great for hot dry conditions, May - June bloom
Viburnum nudum	Winterthur		5 - 7'	berries for birds, May bloom, excellent Fall color

PERENNIALS				
Achillea millefolium	Common yarrow		24 - 36"	Wildflower, no maintenance, July - Sept bloom, Full sun
Actaea racemosa	Black bugbane		4 - 6'	Wildflower, no maintenance, Aug - Sept bloom, Full sun
Agastache foeniculum	Anise hyssop		2 - 4'	Wildflower, no maintenance, late June - Oct bloom, Full sun
Amsonia hubrichtii	Bluestar		36"	Wildflower, little maintenance, May-June flower, fall color, Full sun
Anemone canadensis or virginiana	Buttercup, can be white or yellow color		30"	Wildflower, Summer and Early Spring bloom
Asclepias - multiple varieties	Milkweed		30"	Wildflower, pollinator, all summer bloom, Full sun
Baptisia australis	Blue wild indigo		40"	Wildflower, May bloom, Full sun
Echinacea purpurea	Coneflower		18 - 42"	Wildflower, June - Oct bloom, several varieties, Full sun
Eutrochium purpureum	Joe Pye Weed, low or tall varieties		2 - 4' or 4 - 7'	Wildflower, July - Nov bloom, Full time
Ionactis linariifolia	Aster, several varieties		12 to 6'	Wildflower, late summer, fall blooming, Full sun
Iris versicolor	Blue iris		2 - 3'	Wildflower, May bloom, Full sun
Liatris spicata	Spike, blazing star		12" to 6'	Wildflower, mid summer bloom, purple spikes, Full sun
Lobelia - multiple varieties	Cardinal flower	Great blue	24 - 36"	Wildflower, June - July bloom, Full sun
Lupinus	Lupine		12 - 48"	Wildflower, June Bloom, no maintenance, Full sun
Monarda fistulosa	Wild Bergamot, Bee balm	Marshall's delight, Jacob Cline	24 - 48"	Wildflower, pollinator, all summer bloom, Full sun
Penstemon - multiple varieties	Foxglove, beard tongue	Husker's Red	12 - 36"	Wildflower, blooms May - early July, Full sun but can tolerate partial shade
Phlox - multiple varieties	paniculata = tall, stolonifera = creeping	Paniculata David, Stolonifera sherwood purple etc	9" - 18" or 24 - 36"	Wildflower, paniculata blooms July - Oct; stolonifera blooms April - May
Rudbeckia - multiple varieties	Black eyed susan, Coneflower		24 - 36"	Wildflower, many varieties, blooms June - Nov, Full sun
Solidago - multiple varieties	Goldenrod	low and tall varieties	12 - 6'	Wildflower, many varieties, blooms Aug - November, Full sun
Symphotrichum novae-angliae	New England Aster	numberous varieties		Wildflower, exercise caution here between native and non native species
GROUNDCOVERS				
Arcostaphylos uva-ursi	Bearberry, kinnikinnick		12 - 18"	Shrublike groundcover, red berries, great winter color, Full Sun, Part Shade
Asarum canadense	Wild ginger		6 - 9"	April - June bloom time, can be evergreen with mild winter conditions
Athyrium filix-femina	lady fern		2-5'	very hardy to cold temperatures. Great for wetlands
Dryopteris - multiple varieties	Wood Ferns, Fern family	Eastern wood fern, Goldies' fern	3-4'	shade perennial, can tolerate dry conditions once established
Gaultheria procumbens	Wintergreen, Teaberry		12 - 24"	October berries, low growing woody shrub. Edible, possibly evergreen per conditions
Osmundastrum cinnamomeum	Cinnamon fern		15 - 40"	tall fern, big presence,
Packera aurea	Golden ragwort. Groundsel		6' to 3'	member of the aster family, full sun to part shade, blooms March - May
GRASSES				
Ammophila breviliquata	American beach grass		30-40"	sand dune grass
Andropogon gerardii	Big blue stem		6' - 8'	large root system, bluish red color, tolerates poor soils
Carex appalachica, pensylvanica	Appalachian sedge		8" to 12"	low Sedge grass, no maintenance, blooms, Aug - Oct bloom, Full sun
Chasmanthium latifolium	Sea Oats, fish on a fishing pole		2 - 5'	low growing, groundcover type grass
Eragrostis spectabilis	Purple lovegrass		1-2'	soft purple tones, blooms in late summer, full sun
Sisyrinchium atlanticum	Blue eyed grass		20"	clumping grass, sweet blue flowers, bloom time March - July
Panicum virgatum	Switch grass	Heavy metal or Shenandoah	30" - 10'	Upright and fastigid habit
VINES				
Campsis radicans	Trumpet Vine, Trumpet creeper		10' width	vigorous vine, trumpet shaped flowers
Clematis virginiana	Devil's hair, Wirgin bower		10-20' width	aggressive vine, delicate flower, fall varieties are fragrant
Hydrangea anomala petiolaris	Climbing hydrangea		40' plus	flowering vine, slow to flower, vigorous growth
Lonicera sempervirens	Trumpet honeysuckle		4 to 15'	great for pollinators, red, yellow and orange colors, exercise caution and select the native variety
Parthenocissus quinquefolia	Virginia creeper		70 - 100' width	5 leaf vine, terrific fall red foliage, vigorous vine

Appendix C

Sign Design Checklist

1. Applicant

Name: _____

Phone: _____

Email: _____

Address: _____

2. Building Address

3. Business Type: _____

4. Sign Type:

- | | |
|---------------------------------------|--|
| <input type="checkbox"/> Wall | <input type="checkbox"/> Open/Closed |
| <input type="checkbox"/> Projecting | <input type="checkbox"/> A-Frame |
| <input type="checkbox"/> Freestanding | <input type="checkbox"/> Trade Flag |
| <input type="checkbox"/> Under Canopy | <input type="checkbox"/> Other (Describe): _____ |
| <input type="checkbox"/> Window | _____ |
| <input type="checkbox"/> Awning | |

The following sign types are prohibited in Downtown Hyannis:

- A. Internally illuminated signs
- B. Signs made of plastic or vinyl
- C. Simulated neon signs
- D. Flashing, blinking, scrolling, or video signs or displays. Neon signs shall not flash or blink.
- E. Cabinet or box signs
- F. Molded plastic A-Frame signs
- G. Flat banner signs

5. Sign Material

- Wood
- PVC
- Other (Describe): _____

6. Illumination Strategy

- None
- Backlit / Halo Lit
- External Gooseneck
- Other (Describe): _____

7. Sign Dimensions (in inches)

Height: _____ Width: _____ Depth: _____

Appendix D

Frontage Types

- Legend: **DMS** – Downtown Main Street Zoning District **HH** – Hyannis Harbor Zoning District
DV – Downtown Village Zoning District **TC** – Transportation Center Zoning District
DN – Downtown Neighborhood Zoning District **HC** – Highway Commercial Zoning District
DH – Downtown Hospital Zoning District

P - Permitted	N - Not Permitted	DMS	DV	DN	DH	HH	TC	HC
 <p>A frontage type consisting of a storefront(s) and an attached colonnade with a roof, open pergola, or balcony overhanging a paved sidewalk. A gallery may wrap around the corner of a building to create a veranda-like gallery.</p>		P	P	N	N/A	P	P	P

Table 11. Frontage Types								
P - Permitted	N - Not Permitted	DMS	DV	DN	DH	HH	TC	HC
Storefront		P	P	N	N/A	P	P	P
 <p>A frontage type consisting of an assembly of commercial entry doors and display windows providing access and light to a commercial space and a place to display goods, services, and signs.</p>								

Table 11. Frontage Types								
P - Permitted	N - Not Permitted	DMS	DV	DN	DH	HH	TC	HC
Common Lobby		P	P	N	N/A	P	P	P
 <p>A frontage type consisting of an assembly of entry doors and windows providing access and light to the lobby of a building. A common lobby may be combined with an entry plaza or front garden frontage type.</p>								



Table 11. Frontage Types								
P - Permitted	N - Not Permitted	DMS	DV	DN	DH	HH	TC	HC
Dining Patio  <p>A frontage type consisting of a storefront(s) and outdoor cafe seating in the frontage area.</p>		P	P	N	N/A	P	P	P
Entry Plaza  <p>A frontage type consisting of a storefront(s) and a highly paved frontage area. An entry plaza may be combined with a common lobby frontage type.</p>		P	P	N	N/A	P	P	P

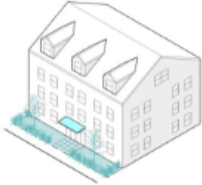
Table 11. Frontage Types								
P - Permitted	N - Not Permitted	DMS	DV	DN	DH	HH	TC	HC
Front Garden		N	P	P	N/A	N	N	N
 <p>A frontage type consisting of a highly landscaped frontage area. A front garden may be combined with a common lobby, dooryard or stoop, or porch frontage type.</p>								

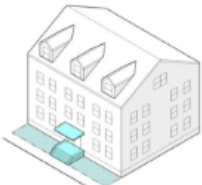
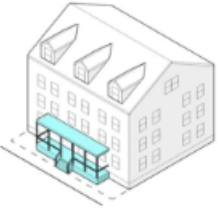
Table 11. Frontage Types								
P - Permitted	N - Not Permitted	DMS	DV	DN	DH	HH	TC	HC
Dooryard or Stoop		N	P	P	N/A	N	N	N
 <p>A frontage type consisting of a zero-step entrance or a set of stairs with a landing that provides access to the entrance of a building. A dooryard or stoop may be combined with a front garden frontage type.</p>								

Table 11. Frontage Types

P - Permitted	N - Not Permitted	DMS	DV	DN	DH	HH	TC	HC
Porch		N	P	P	N/A	N	N	N
 <p>A frontage type consisting of a raised platform with a roof supported by columns, piers, or posts; an area for seating; and an optional set of stairs with a landing that provides access to the entrance of a building. A porch may be combined with a front garden frontage type.</p>								